

Are you familiar with the latest research on [tactical rifle scope with digital zoom](#).

The shooting industry has witnessed significant advancements over the years, with one of the most notable being the integration of digital zoom in tactical rifle scopes. This innovation has revolutionized the way shooters approach their craft, offering a range of benefits that enhance accuracy, convenience, and overall shooting experience. In this article, we delve into the myriad advantages of tactical rifle scopes with digital zoom and how they are reshaping the landscape of the shooting industry.

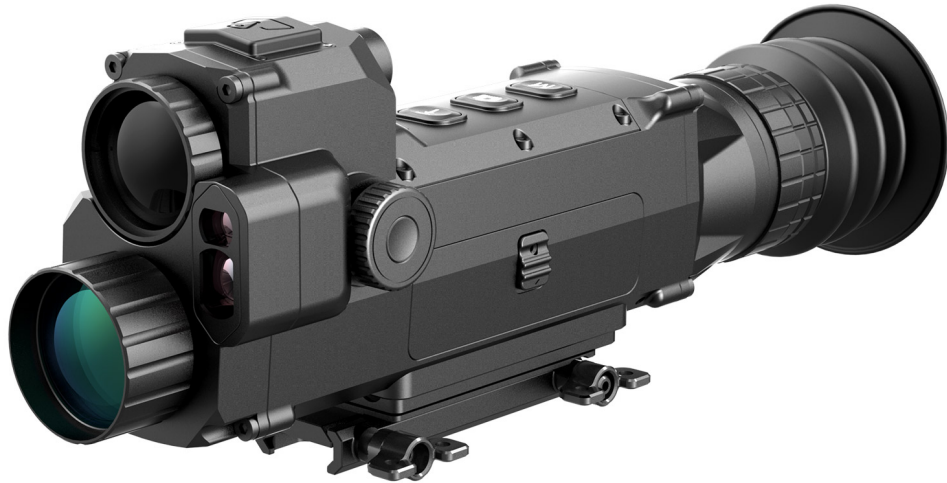

## Enhanced Accuracy and Precision

One of the primary benefits of tactical rifle scopes with digital zoom is the enhanced accuracy they provide. Traditional scopes rely on optical zoom, which can sometimes be limiting in terms of clarity and precision. Digital zoom, on the other hand, allows shooters to magnify their target with greater detail and accuracy. This is particularly beneficial for long-range shooting, where even the slightest miscalculation can result in a missed shot. By offering a clearer and more precise view of the target, digital zoom scopes enable shooters to make more informed decisions and improve their overall accuracy.

## Versatility in Various Shooting Scenarios

Tactical rifle scopes with digital zoom offer unparalleled versatility, making them suitable for a wide range of shooting scenarios. Whether you are engaged in hunting, competitive shooting, or tactical operations, these scopes can adapt to your needs. The ability to quickly adjust the zoom level allows shooters to seamlessly transition between different distances and environments. For instance, hunters can easily switch from a wide field of view for tracking game to a high magnification for taking precise shots. This adaptability makes digital zoom scopes an invaluable tool for shooters of all disciplines.

## Improved User Experience

Another significant advantage of tactical rifle scopes with digital zoom is the improved user experience they offer. Traditional scopes often require manual adjustments, which can be time-consuming and cumbersome. Digital zoom scopes, however, typically feature intuitive controls and user-friendly interfaces that simplify the process. Many models also come equipped with additional features such as reticle customization, ballistic calculators, and rangefinders, further enhancing the shooting experience. These advanced functionalities not only make shooting more enjoyable but also contribute to better performance and results.

## Technological Integration and Future Potential

The integration of digital technology in tactical rifle scopes opens up a world of possibilities for future advancements. As technology continues to evolve, we can expect to see even more innovative features and improvements in digital zoom scopes. For example, augmented reality (AR) overlays could provide real-time data and analytics, helping shooters make more informed decisions. Additionally, advancements in image stabilization and low-light performance could further

enhance the capabilities of these scopes. The potential for growth and innovation in this field is immense, promising exciting developments for the shooting industry.

## **Conclusion**

In conclusion, the benefits of tactical rifle scopes with digital zoom are manifold, offering enhanced accuracy, versatility, improved user experience, and promising future potential. As the shooting industry continues to embrace technological advancements, digital zoom scopes are set to play a pivotal role in shaping the future of shooting. Whether you are a seasoned shooter or a novice, exploring the advantages of these innovative scopes can significantly elevate your shooting experience and performance.

## **References**

- [tactical rifle scope with digital zoom](#)